

**PMU-VKS
with TKKR**
Duct sensor
up to 150° C

**PMU-VGS
with TWKR**
wall-mounting

**PMU-V
with TVKR**
Rod-shaped sensor

**PMU-VZS.H
with TWKR**
(sensor part
applicable up to
200° C)

**PMU-VZS.HD
with TWKR...**
(sensor part
applicable up to
160° C
and 25 bar)

PM-VS

Sensors for humidity and temperature with RS232 signal level converter

for digital transfer of the measurement values
 Rod and industrial designs
 up to 200°C and up to 25 bar

with **exchangeable** „Plug and Measure Units“ PMU

Description

The PM-VS transmitters by Galltec+Mela combine digital plug-and-measure technology with the advantages of industrial sensors which can be used up to a temperature of 200°C, or respectively, up to a pressure of 25 bar and are thus particularly suitable for use in demanding industrial applications. They consist of the calibrated Plug-and-Measure Unit PMU... and a RS232 transmitter. The various transmitters and PMU can be mixed and matched with each other, according to the physical and mechanical requirements.

The capacitively measured humidity and temperature values are calculated in the calibrated Plug-and-Measure Unit PMU, with the calibration values stored there, and are passed on as digital measurement values. The PMU measuring heads can be factory-calibrated and readjusted using software.

This line of sensors has got a digital RS232 output and is suitable for data transfer via the network and the Internet. This line of sensors is designed for a permanent connection. The scope of delivery includes a PTFE pocket filter and the stainless steel filter ZE04

Technical Data for Humidity and Temperature

Humidity

measuring range 0...100% rh
 measuring accuracy 10...90% rh at 23° C ±1.5% rh
 at <10%rh or >90%rh ±2%rh
 at <10°C or >40°C ±0.05%rh/K additional
 resolution 0.01%rh (read out)
 hysteresis < 1%rh
 response time t_{63} at v=2m/s
 with PTFE pocket filter < 15 s
 protection against dust PTFE pocket filter

Temperature

measuring element Pt1000 1/3DIN
 measuring range -40...+85°C
 measuring accuracy ±0.15 K at 23°C
 resolution 0.01K (read out)
 influence of temperature (TK) <0.005 K/K
 response time t_{63} at v=2m/s
 with PTFE pocket filter < 15 s

General Technical Data

measuring medium air, non-aggressive
 supply voltage, external 5...30 VDC
 or RS232 level (RTS, DTR)
 consumption of electronics < 7 mA
 max. guaranteed transfer distance for RS232 15 m
 max. ambient temperature at the transmitter -40...85° C
 degree of protection transmitter IP65
 measuring head (PMU) IP00
 connector PMU-->transmitter IP67
 material of housing
 sensor part stainless steel
 transmitter part aluminium die-casting
 Directive about electromagnetic compatibility **2004/108/EG**
 DIN EN 61326-1 issue 10/06
 DIN EN 61326-2-3 issue 05/07

Order designation of measuring heads

Type of PMU	Order no.	Output range ¹⁾	
		rel. humidity	temperature
PMU-V	620101023538	0 ... 100 % rh	-40...+85°C
PMU-VKS	as description	0 ... 100 % rh	-50...+150°C
PMU-VZS.H	as description	0 ... 100 % rh	-60...+200°C
PMU-VZS.HD	as description	0 ... 100 % rh	-60...+200°C

¹⁾ Output range = max. ambient temperature for the measuring head

Special types on demand

Order designation of RS232 transmitter

Type of transmitter = order no.	max. ambient temperature	Mounting versions
TVKR.00.F148.500.xx3 ²⁾	-40 ... +85°C	cable for suspension or with wall bushings ZA24
TWKR.00.F192.500.000	-40 ... +85°C	wall mounting
TKKR.00.F155.500.000	-40 ... +85°C	duct mounting

²⁾Length of connecting cable in m

Operating software HyperTerminal (Windows)

The sensors in the series PM-VS can be read via the Hyper Terminal programme from Windows. The picture below shows the character string of the data issued by the PMU.

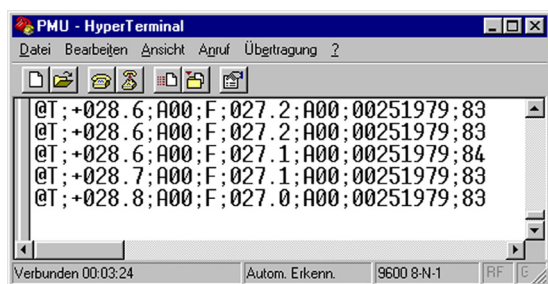

Connection settings

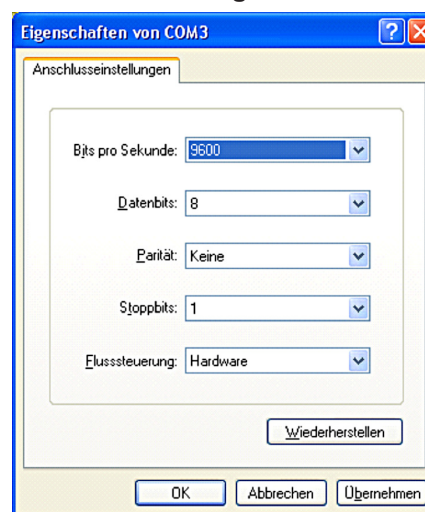

Notes on ASCII protocol

start of protocol	end of protocol	separation sign
@	"CR" and "LF"	“, “

The measurement data is sent in the measurement phase as ASCII-protocol on the TxD-pin:

@T	<sign>	<temperature>	<alarm-code>	F	<humidity>	<alarm-code>	<serial number>	<check-sum>	<CR>	<LF>
----	--------	---------------	--------------	---	------------	--------------	-----------------	-------------	------	------

Example:

@T; + 021.37; A00; F; 038.92; A00; 00000121; 38 control character Carriage Return control character Line Feed

The check sum is calculated as follows:

$$\text{check sum} = 255 - (\sum_{\text{dez}} \% 256) = \text{check sum}_{\text{dez}} = \text{check sum}_{\text{hex}}$$

Example:

$$\text{check sum} = 255 - (1991 \text{ Modulo } 256) = 255 - 199 = 56 = 38_{\text{hex}}$$

The check sum is not transmitted as a hexadecimal character with 1 byte, but is translated into readable digits with 2 bytes. Through the comparison of the transmitted check sum with a check sum calculated at the read-out point, the user has the opportunity to check whether the transmission of the data is error-free.

Alarm codes:

Temperature channel:	Humidity channel:
A00 = no alarm, the temperature value is within the limits	A00 = no alarm, the humidity value is within the limits
A01 = temperature measurement range exceeded	A01 = humidity measurement range exceeded (=100% rh)
A02 = below temperature measurement range	A02 = below humidity measurement range (= 0% rh)
A03 = no sensor signal	A03 = no sensor signal
A04 = short circuit at PT1000 (resistance < 500 Ω)	A04 = humidity sensor defective

Software „VisualPMU“ (Freeware)

This simple and very clear visualisation software supports the data output of a sensor via a serial interface on the PC or Laptop without an additional power supply.

For this, it is necessary to install the accessory *Sub-D data line*. For USB connections, a *USB adapter* can be supplied.

The relative humidity, the dew point and the temperature (°C or F) can be displayed and can be depicted as a graph. Apart from that, the programme has a simple data logger function. Recorded data can be exported to other programmes.

This freeware version can be obtained from our Homepage www.galltec-mela.de as a free of charge download.

Accessories

Description	Product no.	Data sheet	Description
Sub-D data line RS232	PMVS.02	-	Sub-D data line 2.5m <i>Caution: jack on data line IP30 / -10...50°C !</i> When using the TVKR.00.0000.500.000, a commercially available 9 pin Sub-D jack can be mounted at the end of the cable, <i>for wiring diagram see connection diagrams !</i>
USB adapter serial >USB	USB adapter	-	USB adapter for Sub-D data line <i>To connect up the Sub-D-data line to a USB interface on the PC or Laptop</i>
ZA 24	as description	F5.1	Attachment plate for attaching ducts or wall bushings for sensor tubes 15 mm
ZA 161/1 with adapter sleeve 00.502	as description	F5.1	Weather protection for rod sensors <i>recommended for outside use to protect from rainfall and sunlight</i> with adapter sleeve 00.502 also suitable for rod sensors 15 mm
6 x AWG26C-UL	5303		Shielded cable, interference immunity according to EN 61326 <i>recommended for connecting the sensors via EMC screw connection of the sensor</i> <i>Fitting the cable in the EMC screw connection must be done by a professional.</i>
ZE 31/1-12 ZE 31/1-33 ZE 31/1-75 ZE 31/1-84 ZE 31/1-94	as description	F5.2	Standard humidity to check the accuracy of the sensors 12 %rh and 25°C Standard humidity to check the accuracy of the sensors 33 %rh and 25°C Standard humidity to check the accuracy of the sensors 75 %rh and 25°C Standard humidity to check the accuracy of the sensors 84 %rh and 25°C Standard humidity to check the accuracy of the sensors 94 %rh and 25°C
ZE33	as description	F5.2	Adapter for humidity standard ZE 31/1

User information

Installation

The sensors are to be attached in a position representative for the climate measurement

The position the sensor is mounted in (horizontal, vertical) does not matter. However, it should be mounted in such a way that no water can get into it.

Please note the maximum permissible ambient temperature for PMU and transmitter when installing it. The transmitters always have to be installed in such a way that the connection plugs are not exposed to a higher temperature either (>85°C).

The duct sensor PMU-VKS is mounted with an insulation length of 134 mm for use at 150°C (refer to dimension drawing).

Caution! The tightening torque when installing the pressure-resistant sensors (type PMU-VZS.HD) may not exceed 25 Nm.

In a clean environment, the sensor is maintenance-free.

The capacitive MELA sensor element is also protected by the integrated PTFE filter. Dust does not cause any harm to the humidity sensor, however, if there is an increased build-up of dust this does affect dynamic performance.

If there is an excessive build-up of dust then you can carefully unscrew the filter and rinse it with distilled water. Loose dirt can also be removed from the PTFE filter above the measuring element by blowing it off or rinsing it carefully

with distilled water.

Dew formation and splashes do not damage the sensor, although corrupted measurement readings are recorded until all the moisture on and directly around the sensor element has dried up.

Damaging Influences

Agents that are corrosive and contain solvents, depending upon the type and concentration of the agent, can result in faulty measurements and cause the measuring element to break down. Substances deposited on the sensor are damaging as they form a water-repellent film (this applies to all humidity sensors with hygroscopic measuring elements); e.g. resin aerosols, lacquer aerosols, smoke deposits etc. In order to check functioning in the place of installation, we recommend that you use our *ZE31/1-type humidity standard... (accessories)*.

To ensure the given accuracy of the sensors, we recommend a calibration cycle of 6-12 months.

Additional information

Please consult the **application instructions** for the sensing elements (product info sheet no. A 1 and B1.1), which you can get from www.galltec-mela.de, for further information which you need to bear in mind when using humidity sensors with capacitive sensing elements.

Dimensions

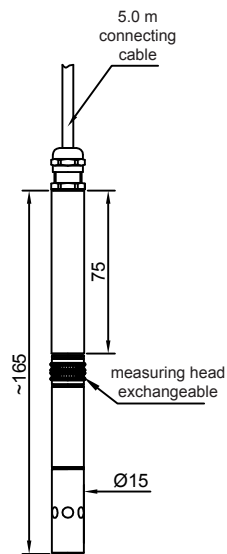

PMU-V
with TVKR...
rod-shaped sensor,
-40...85°C

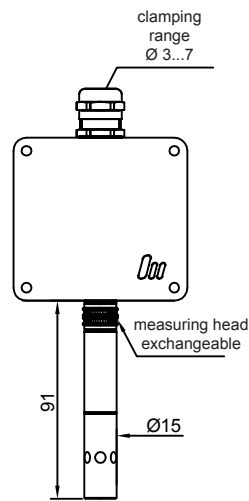

PMU-VGS
with TWKR...
wall-mounting,
-40...85°C

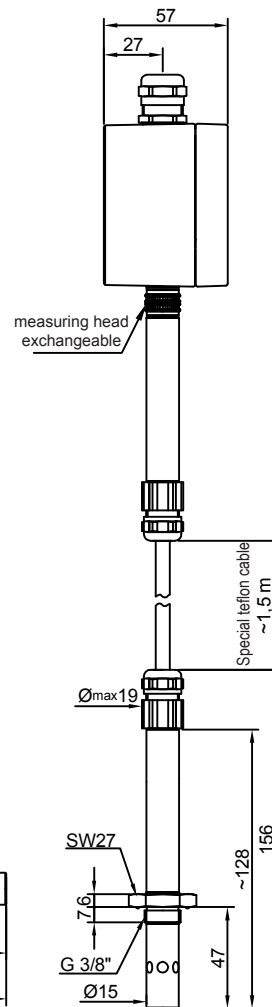

PMU-VZS.HD
with TWKR...
sensor up to 25 bar,
up to 160°C

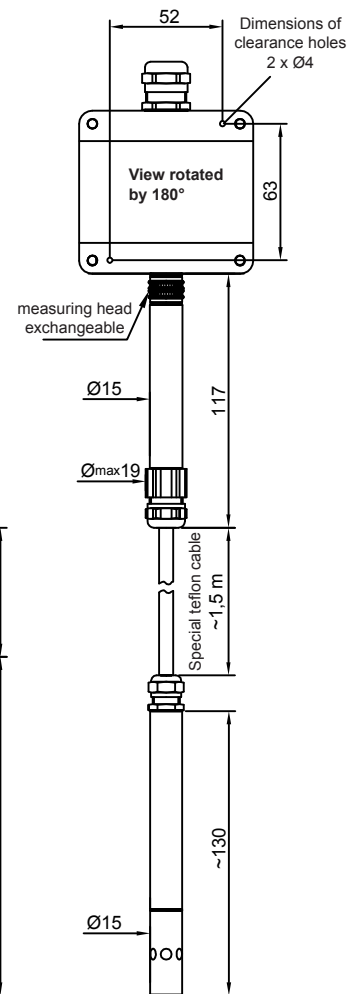

PMU-VZS.H
with TWKR...
sensor up to 200°C

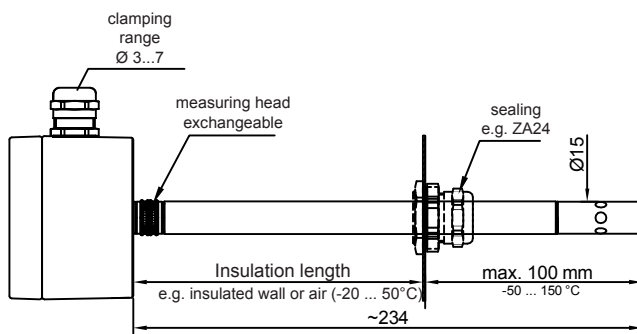

PMU-VKS with TKKR...
duct mounting, up to 150°C

Connection diagrams

