

**Product info sheet**

**Condensation detector to prevent the building of condensed water**

**FAS**



**Type Survey**

Type	Order no.	Contact type
FAS	42088012	changeover contact with silver contacts
FAS	42087012	changeover contact with gold contacts
FAS 250V AC	42081012	changeover contact with silver contacts  see data sheet FAS 250VAC

**Technical Data**

range of operation ..... 50...90%rh  
 breaking capacity  
 max. 48VAC and  
 0,1 ... 5A ohmic load for dehumidifying  
 0,1 ... 2A ohmic load for humidifying  
 0,1 ... 1A for inductive load (power factor >0.8)  
 lifetime ..... > 6.000 breaking cycles  
optional microswitch with gold contacts  
 breaking capacity  
 max. 48 VAC and  
 1...100 mA  
  
 optional FAS up to a maximum of 250V AC available  
 see separate data sheet at  
 www.galltec-mela.de

allowable ambient temperature ..... 0...60°C  
 air-speed ..... 0.2...8 m/s  
 installation altitude ..... ≤ 4.000m above sea level  
 influence of temperature  
 ref. to 23 °C ..... ≤ +/- 0.2 % r.h. / K  
 typ. response time  $t_{50}$  at v=2m/s ..... 1.2min  
 mounting position ..... as you like  
 contacting ..... connecting terminal in the case  
 purpose of sensing control ..... humidity sensing control  
 nominal cross-sectional area of the conductors.....  
 ..... up to 2.5 mm<sup>2</sup> for fixed wiring conductors (single wire)  
 ..... up to 1.5 mm<sup>2</sup> for flexible cord conductors (fine-stranded)  
 type of protective earth conductor ..... bow terminal  
 action ..... 1.C.L  
 degree of pollution ..... 3  
 rated impulse voltage ..... 4kV  
 ball indentation test for temperature ..... 92°C  
 applied directives / standards  
 low-voltage directive 2014/35/EU  
 EMC directive 2014/30/EU  
 DIN EN 60730-1:2012-10  
 DIN EN 60730-2-13:2008-09  
 protective system ..... IP20  
 measuring element .....  
 .....Polyga®-measuring element, water resistant  
 dimensions ..... 85x55x33mm  
 weight ..... approx. 80 g

**Description of the switch**

The hygrostat module on PCB with Polyga® measuring element is arranged on an aluminium base plate so that the measuring element is in an immediate proximity to the base plate. Protected by the housing, relative humidity near to dew point can form inside. The aluminium plate is adjacent to the cooling pipe and transfers the cold to the measuring element. The set point can be set inside and has to be adapted to the local conditions. The microswitch of the hygro module switches a changeover contact potential-free. The standard switch is lined with silver contacts. Optionally there is a microswitch with gold contacts. The FAS does not require a supply voltage resp. auxiliary energy.

**Adjusting the break point**

It is important to set the correct break point for the equipment. A setpoint value that is too high can cause dew to form as the conditions at the measuring point are not constant. The measuring point of the humidity controller should be selected such that there is no build-up of condensate on or in the device. Tests have shown that good results are achieved at a break point of 80%rh. The break point can be adapted to the equipment. Open the covering cap for that purpose and finely adjust the break point.

This information is based on current knowledge and is intended to provide details of our products and their possible applications. It does not, therefore, act as a guarantee of specific properties of the products described or of their suitability for a particular application. It is our experience that the equipment may be used across a broad spectrum of applications under the most varied conditions and loads. We cannot appraise every individual case. Purchasers and/or users are responsible for checking the equipment for suitability for any particular application. Any existing industrial rights of protection must be observed. The perfect quality of our products is guaranteed under our General Conditions of Sale. Issue : June 2016 FAS\_E. Subject to modifications.

**Connection diagram**

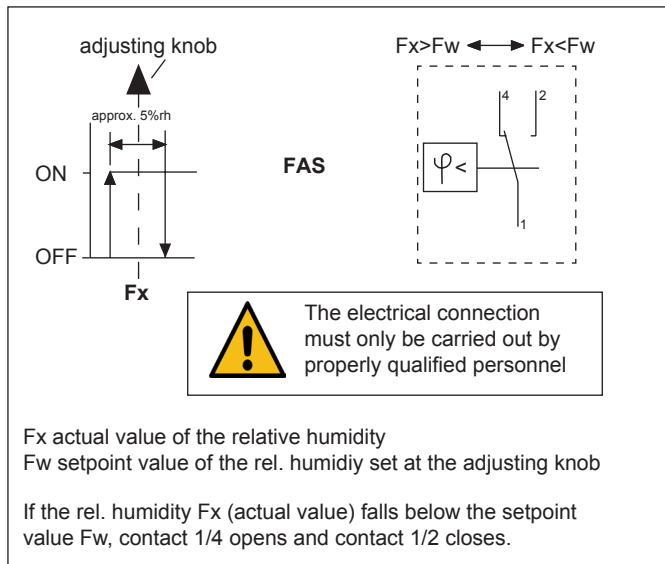

**Dimensions diagram**

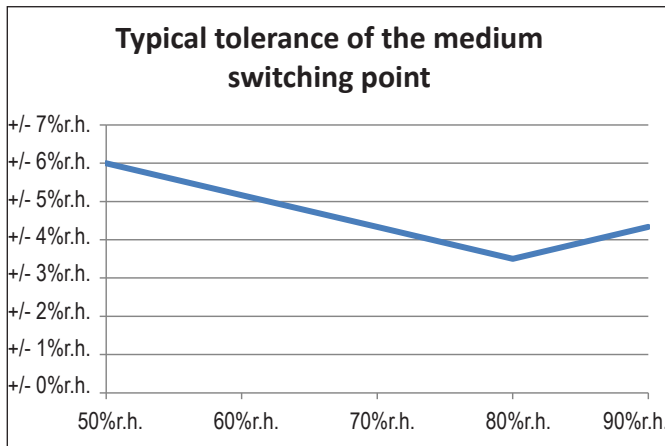
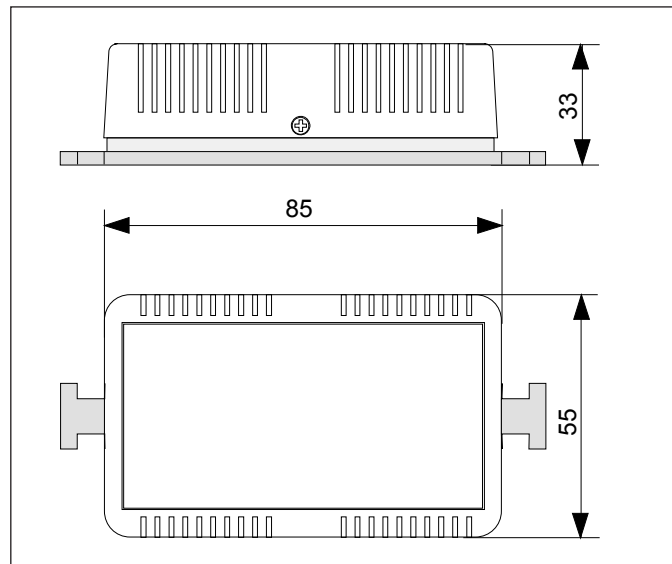

Long-term drift:  $\leq \pm 1\%r.h.$  p.a.

**Typical switching differential with typical tolerance**

Setpoint value humidity	Switching differential	Tolerance
50 % r.h.	5 % r.h.	+/- 1,5 % r.h.
60 % r.h.	4 % r.h.	+/- 1,5 % r.h.
70 % r.h.	4 % r.h.	+/- 1,5 % r.h.
80 % r.h.	3 % r.h.	+/- 1 % r.h.
90 % r.h.	3 % r.h.	+/- 1 % r.h.

**Contact with the measuring mechanics of the device nullifies the warranty.**

**Notes on use**

If condensed water formation is to be monitored in a room, the most humid position should first be established. The coldest position does not necessarily have to be the most humid position (see hx diagram). Please ensure that any changes in the room do not result in a different, more humid spot. The condensation detector FAS must be mounted in such a way that there is good heat contact with the selected position. Please note also that any condensate must not get into the interior of the housing. Attachment is made by using the supplied binders which can be used for pipes with diameters of up to 50mm. The housing must not be exposed to any outside heat as this may cause incorrect measurements.

The mounting location should be chosen so that a representative measurement of the air humidity can be guaranteed, i.e. the ambient air must be able to reach the measuring element within the casing without obstacles. The FAS should be exposed to the flow of air with a minimum air speed of 0.2 m/s.

**Maintenance**

The measuring element is maintenance-free in pure ambient air. Aggressive media containing solvent can cause measuring errors depending on the type and concentration. Deposits which eventually form a water-repellent film over the measuring element are harmful (such as resin aerosols, lacquer aerosols, smoke deposits etc.).

No warranty is provided for defects and damage caused either by improper use or by any interference with internal components.