



Function

A reproducible water vapour partial pressure develops over a saturated saline solution in a closed system. The saline solutions yield water when the salt is separated off or absorb water, with undissolved salt going into the solution. These processes continue until the water vapour pressure of the volume of air on the top is the same as that of the saturated saline solution. The relative humidity which forms in the volume of air (testing chamber) is dependent on the saline solution and the temperature of the solution. The testing chamber and the saline solution are separated by a membrane which is permeable to water vapour.

Instructions for use

The humidity sensor and humidity standard have to be at the same temperature during the test, otherwise this may lead to inaccurate results. The temperature may be between 10...40 °C but must remain constant during the test. The sensors should be stored at a constant humidity of between 30 and 50%rh for about 24 hours before the test.

The saline solution in the humidity standard should be checked before every test procedure because the values specified in the table can only be achieved via a saturated saline solution. This should be checked visually. A saturated saline solution exists if there is still enough undissolved salt visible.

When working with the humidity standard, ensure that the testing chamber is only opened briefly for the purposes of taking in the sensing element; otherwise, there will be a constant exchange of humidity between the saline solution and the ambient air.

If the testing chamber is open, LiCl and MgCl₂ for example, draw water from the ambient air, and NaCl and KCl dry out. Whenever the humidity standard is not in use, it must be stored with its lid tightly sealed at all times.

Product info sheet no. F 5.2

Accessories

humidity standards

Description

The ZE 31/1-series humidity standards are used as a simple and reliable way of checking Mela® humidity sensors on-site or in the laboratory. The following humidity standards are available:

Type versions	Type (order designation)
empty container	ZE 31/1
12%rh at 25°C	ZE 31/1-12
33%rh at 25°C	ZE 31/1-33
75%rh at 25°C	ZE 31/1-75
84%rh at 25°C	ZE 31/1-84
94%rh at 25°C	ZE 31/1-94

Humidity values depending on the ambient temperature:

Temp.	LiCl	MgCl ₂	NaCl	KCl	KNO ₃
10°C	12%	34%	76%	87%	96,0%
15°C	12%	33%	76%	86%	95,4%
20°C	12%	33%	75%	85%	94,6%
25°C	12%	33%	75%	84%	93,6%
30°C	12%	32%	75%	83%	92,3%
35°C	12%	32%	75%	83%	90,8%
40°C	12%	32%	75%	82%	89,0%

Reproducibility: ±2%rh

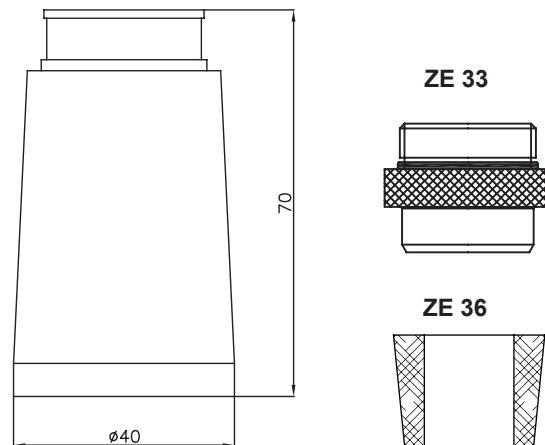

Testing

The **ZE 31/1-series humidity standards** are suitable for testing Mela® humidity sensors and modules with the following product info sheets:

Product info sheet no. B 1.4, series GM, VM

Product info sheet no. C 2.2, 2.3, 2.4, 2.5, 2.7, 2.8, 4.2, 4.7, 4.8 and D series

The test is ideally performed with the sensing elements pointing down vertically (comply with the conditions of use in the data sheet).

Application instructions

For sensors with a diameter of 20 mm (C2.3, C2.4, C2.5, C2.8 and C4.7 - version ...CG-), carefully unscrew the protective basket from the sensor and mount the **test adapter type ZE 33** on the sensor. The sensor with the test adapter mounted on it is then introduced into the humidity standard.

For sensors with a diameter of 15 mm (C4.2, C4.4, C4.7 and C4.7 - with the exception of version ...CG and C4.8), the test adapter type ZE33 is plugged on so that approx. 30 mm of the sensor tip protrudes from the adapter. The sensor with the test adapter mounted on it is then introduced into the humidity standard.

To ensure that test room is completely sealed, the O-rings must not be damaged or removed.

For sensors with a diameter of 12 mm (C2.7, and D series) the **test adapter type ZE36** is plugged on so that approx. 30 mm of the sensor tip protrudes from the adapter. The sensor with the test adapter mounted on it is then introduced into the humidity standard.

CAUTION !

When introducing the sensor into the humidity standard, make sure that the tip of sensor does not destroy the base membrane of the container.

After being separated from the supply voltage the humidity standard should remain on the sensor for at least two hours; complete adaptation to the humidity in the testing chamber takes about 24 hours. Pay attention to the temperature equilibrium between the sensor, the humidity standard and the ambient air. Supply voltage must only be put on during the calibration procedure. The humidity standards cannot be used for recalibration.

Never touch the highly sensitive surface of the sensing element!